

MIQ/JB

IQ SENSOR NET BRANCHING MODULE

Copyright © 2017 Xylem Analytics Germany GmbH
Printed in Germany.

MIQ/JB - List of contents

1	Overview	4
1.1	How to use this component operating manual	4
1.2	Features of the MIQ/JB	5
2	Safety instructions	6
2.1	Safety information	6
2.1.1	Safety information in the operating manual	6
2.1.2	Safety signs on the product	6
2.1.3	Further documents providing safety information 6	
2.2	Safe operation	7
2.2.1	Authorized use	7
2.2.2	Requirements for safe operation	7
2.2.3	Unauthorized use	7
2.3	User qualification	7
3	Installation	8
3.1	Scope of delivery	8
3.2	Installation in the IQ SENSOR NET	8
3.3	Electrical connections: General instructions	8
4	Maintenance and cleaning	11
4.1	Maintenance	11
4.2	Cleaning	11
5	Technical data	12
5.1	General data	12
5.2	MIQ/JB	14

1 Overview

1.1 How to use this component operating manual

Structure of the IQ SENSOR NET operating manual

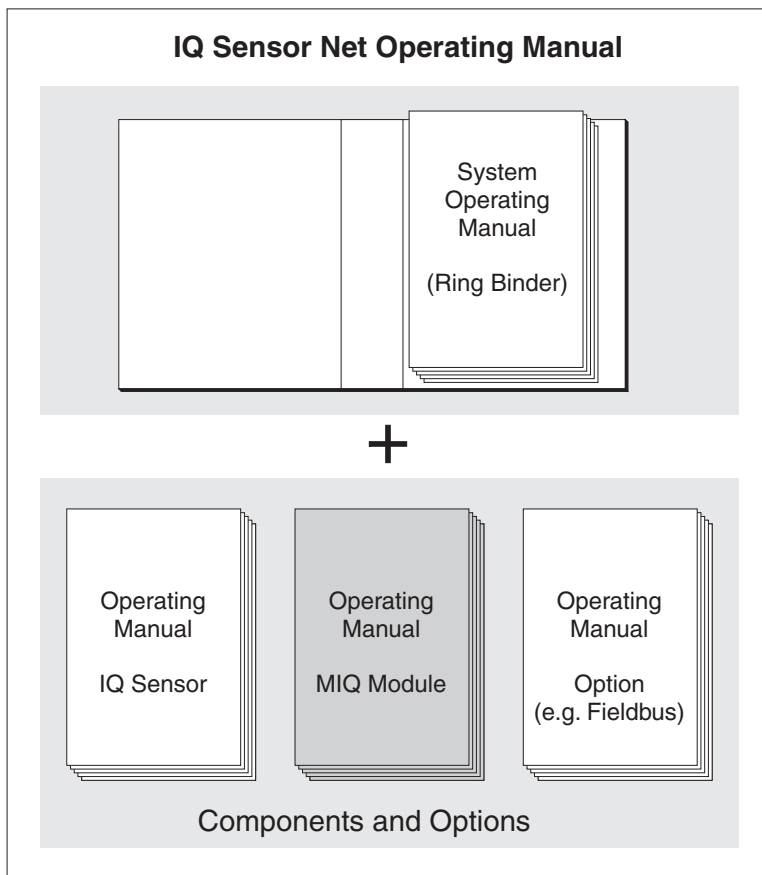

Fig. 1-1 Structure of the IQ SENSOR NET operating manual

The IQ SENSOR NET operating manual has a modular structure like the IQ SENSOR NET system itself. It consists of a system operating manual and the operating manuals of all the components used.

Please file these component operating manuals into the ring binder of the system operating manual.

1.2 Features of the MIQ/JB

General characteristics

The MIQ/JB branching module is used for the distributed mounting of the IQ SENSOR NET. It can be mounted at any position in a cable section.

The branching module can be used, for example, for:

- the branching of the IQ SENSOR NET, e.g. in order to integrate several measurement locations spread out in the system
- the multiple connection of sensors via the SACIQ sensor connection cable, e.g. at the edge of the basin
- setting up an operating site, i.e. the branching module provides a possibility for the docking of terminal components.

The MIQ/JB simplifies the star-shaped configuration of the IQ SENSOR NET for the optimum power supply of all components by power supply modules (see chapter INSTALLATION of the IQ SENSOR NET system operating manual). If necessary, the number of available connections at a single location can be increased by stacked mounting of further MIQ modules.

With the standard MIQ module housing, the MIQ/JB has the same characteristics as all MIQ modules regarding stability, leakproofness and weather resistance. It also provides the same wide variety of installation options (stacked mounting, canopy mounting, tophat rail mounting, etc.).

As many branching modules as required can be installed in a single IQ SENSOR NET system.

Terminal strip

The MIQ/JB has four equal SENSORNET connections on the terminal strip inside the housing that can be used for all the purposes described above.

2 Safety instructions

2.1 Safety information

2.1.1 Safety information in the operating manual

This operating manual provides important information on the safe operation of the product. Read this operating manual thoroughly and make yourself familiar with the product before putting it into operation or working with it. The operating manual must be kept in the vicinity of the product so you can always find the information you need.

Important safety instructions are highlighted in this operating manual. They are indicated by the warning symbol (triangle) in the left column. The signal word (e.g. "CAUTION") indicates the level of danger:

**WARNING**

indicates a possibly dangerous situation that can lead to serious (irreversible) injury or death if the safety instruction is not followed.

**CAUTION**

indicates a possibly dangerous situation that can lead to slight (reversible) injury if the safety instruction is not followed.

NOTE

indicates a situation where goods might be damaged if the actions mentioned are not taken.

2.1.2 Safety signs on the product

Note all labels, information signs and safety symbols on the product. A warning symbol (triangle) without text refers to safety information in this operating manual.

2.1.3 Further documents providing safety information

The following documents provide additional information, which you should observe for your safety when working with the measuring system:

- Operating manuals of other components of the IQ SENSOR NET system (power supply modules, controller, accessories)
- Safety datasheets of calibration and maintenance equipment (e.g. cleaning solutions).

2.2 Safe operation

2.2.1 Authorized use

The authorized use of the MIQ/JB consists of its use as a branching module in the IQ SENSOR NET. Only the operation according to the instructions and technical specifications given in this operating manual is authorized (see chapter 5 TECHNICAL DATA). Any other use is considered unauthorized.

2.2.2 Requirements for safe operation

Note the following points for safe operation:

- The product may only be operated according to the authorized use specified above.
- The product may only be operated under the environmental conditions mentioned in this operating manual.
- The product may only be supplied with power by the energy sources mentioned in this operating manual.
- The product may only be opened if this is explicitly described in this operating manual (example: connecting electrical lines to the terminal strip).

2.2.3 Unauthorized use

The product must not be put into operation if:

- it is visibly damaged (e.g. after being transported)
- it was stored under adverse conditions for a lengthy period of time (storing conditions, see chapter 5 TECHNICAL DATA).

2.3 User qualification

Target group	The IQ SENSOR NET system was developed for online analysis. Some maintenance activities, e.g. changing the membrane caps in D.O. sensors, require the safe handling of chemicals. Thus, we assume that the maintenance personnel is familiar with the necessary precautions to take when dealing with chemicals as a result of their professional training and experience.
Special user qualifications	The following installation activities may only be performed by a qualified electrician: <ul style="list-style-type: none">● Connection of the MIQ/JB to the power supply.● Connection of external, line voltage-carrying circuits to relay contacts (see module manual of the relay output module).

3 Installation

3.1 Scope of delivery

- MIQ module
- Accessory set, including:
 - 4 x cable glands (clamping range 4.5-10 mm) with seals and blind plugs
 - 4 x ISO blind nuts M4 with suitable cheese-head screws and plain washers
 - 2 x countersunk screws M3x6 to close the module lid (+ 2 replacement screws)
 - 1 x contact base with fixing screws
- Operating manual.

3.2 Installation in the IQ SENSOR NET

The IQ SENSOR NET provides a number of options for integrating the MIQ/JB mechanically and electrically in the system (stacked mounting, distributed mounting, etc.). The various types of installation are described in detail in the INSTALLATION chapter of the system operating manual.

3.3 Electrical connections: General instructions

Cable glands All electric cables are fed from below via prepared openings in the enclosure of the MIQ/JB. Cable glands with different clamping ranges are included with the MIQ/JB to provide sealing between the cable and enclosure as well as for strain relief. Select the matching cable gland for the respective cable diameter:

- **Small**, clamping range 4.5 to 10 mm. This cable gland is suitable for all IQ SENSOR NET sensor cables.

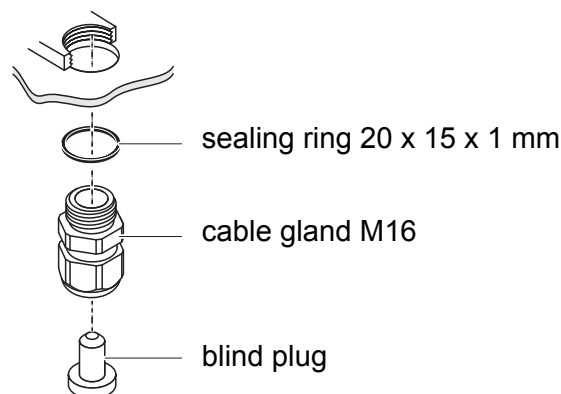

- **Large**, clamping range 7 to 13 mm. This cable gland is required for cable

sheaths with an outside diameter of more than 10 mm and is screwed into the enclosure via an extension piece.

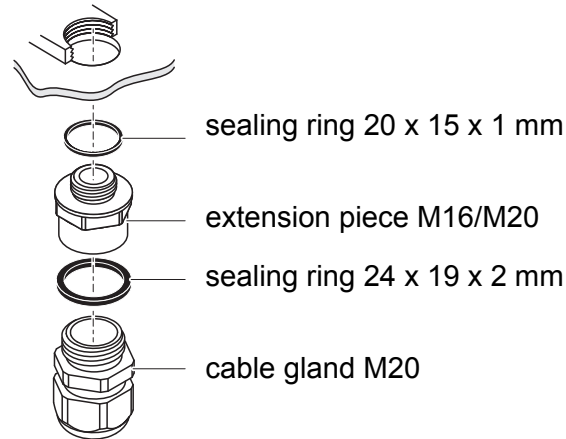

If necessary, you can order more large cable glands in a set of 4 pieces (Model EW/1, Order No. 480 051).

General installation instructions

Observe the following points when attaching connecting wires to the terminal strip

- Shorten all wires to be used to the length required for the installation
- Always fit all the ends of the wires with wire end sleeves before connecting them to the terminal strip
- Any wires that are not used and project into the enclosure must be cut off as closely as possible to the cable gland.
- Screw a small cable gland with sealing ring into each remaining free opening and close it with a blind plug.

Terminal strip

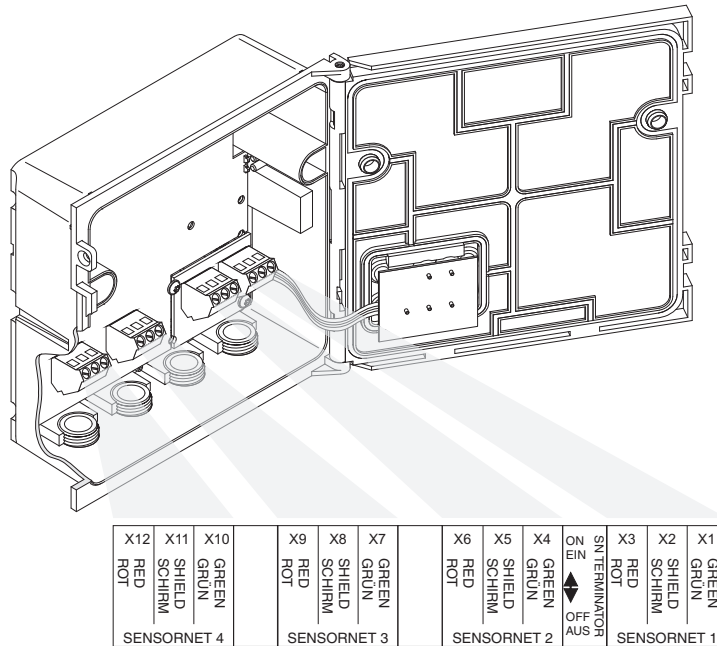

Fig. 3-1 Terminal strip of the MIQ/JB

All SENSORNET connections are identical and can be used as required for extending/branching the cable section or for the connection of sensors.

4 Maintenance and cleaning

4.1 Maintenance

The MIQ/JB requires no special maintenance. The general maintenance of IQ SENSOR NET components is described in the IQ SENSOR NET system operating manual.

4.2 Cleaning

The cleaning of IQ SENSOR NET components is described in the IQ SENSOR NET system operating manual.

5 Technical data

5.1 General data

Dimensions

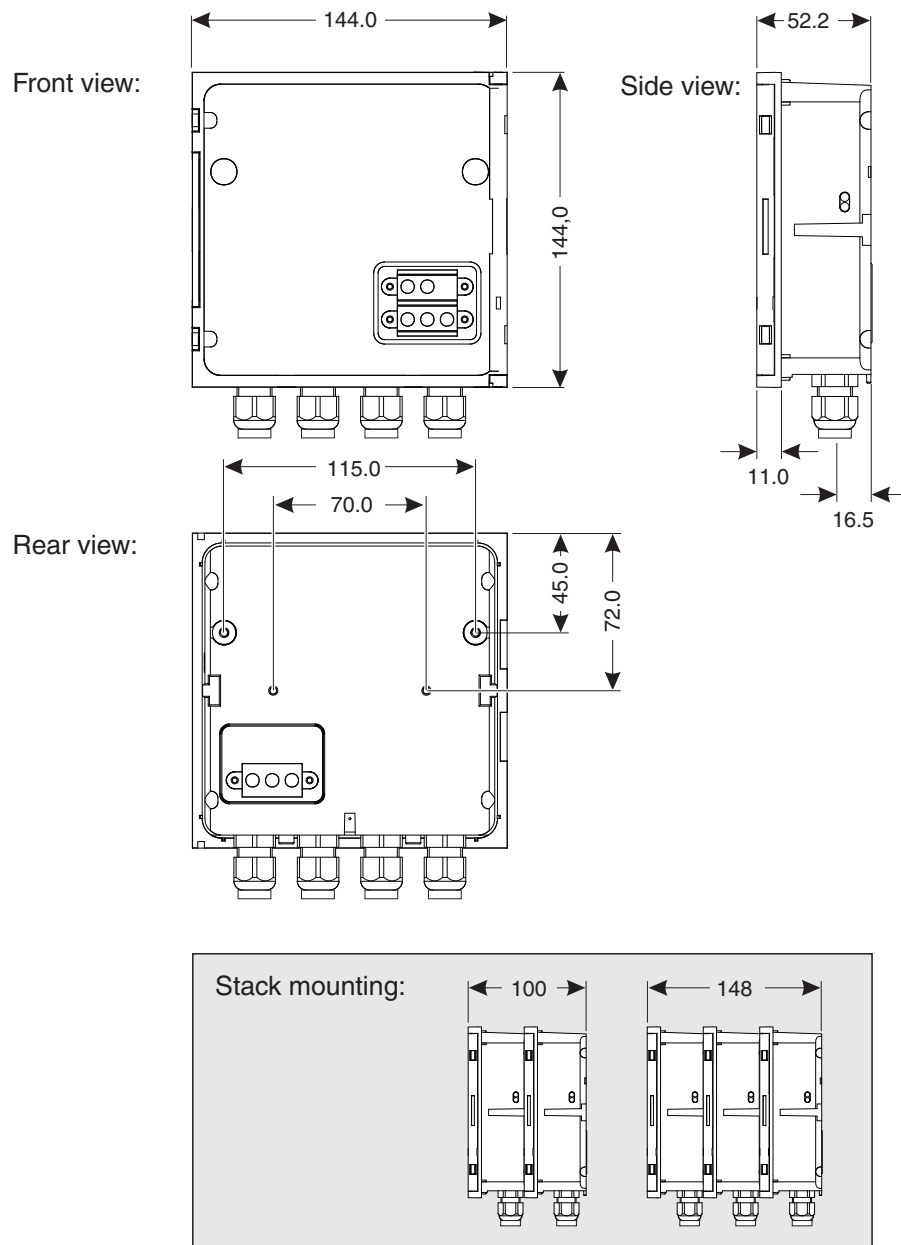

Fig. 5-1 Dimension drawing of MIQ module (dimensions in mm)

Mechanical structure

Maximum number of MIQ modules in a module stack

3

Enclosure material

Polycarbonate with 20 % glass fiber

	Weight	Approx. 0.5 kg
	Type of protection	IP 66 (not suitable for conduit connection).
Cable glands	Suitable for cable sheath diameter	4.5 - 10 mm or 9.0 - 13 mm
Ambient conditions	Temperature	
	Mounting/installation/maintenance	+ 5 °C ... + 40 °C (+ 41 ... +104 °F)
	Operation	- 20 °C ... + 55 °C (- 4 ... + 131 °F)
	Storage	- 25 °C ... + 65 °C (- 13 ... + 149 °F)
	Relative humidity	
	Mounting/installation/maintenance	≤ 80 %
	Yearly average	≤ 90 %
	Dew formation	Possible
	Site altitude	Max. 2000 m above sea level
Meter safety	Applicable norms	<ul style="list-style-type: none"> - EN 61010-1 - UL 61010-1 - CAN/CSA C22.2#61010-1
EMC product and system characteristics	EN 61326	<p>EMC requirements for electrical resources for control technology and laboratory use</p> <ul style="list-style-type: none"> - Resources for industrial areas, intended for indispensable operation - Interference emission limits for resources of class A
	System lightning protection	Noticeably extended qualitative and quantitative protective characteristics as opposed to EN 61326
	FCC, class A	

5.2 MIQ/JB

Electrical data	Nominal voltage	Max. 24 VDC via the IQ SENSOR NET (for details, see chapter TECHNICAL DATA of the IQ SENSOR NET system operating manual).
	Power consumption	Approx. 0.1 W
	Protective class	III
Terminal connections	IQ SENSOR NET connections	4 Additional connectable SENSORNET terminator (terminating resistor)
	Terminal type	Screw-type terminal strip, accessible by raising the lid
	Terminal ranges	Solid wires: 0.2 ... 4.0 mm ² AWG 24 ... 12 Flexible wires: 0.2 ... 2.5 mm ²
	Cable feeds	4 cable glands M16 x 1.5 on the underside of the module

Xylem |'zīləm|

- 1) The tissue in plants that brings water upward from the roots;
- 2) a leading global water technology company.

We're a global team unified in a common purpose: creating advanced technology solutions to the world's water challenges. Developing new technologies that will improve the way water is used, conserved, and re-used in the future is central to our work. Our products and services move, treat, analyze, monitor and return water to the environment, in public utility, industrial, residential and commercial building services settings. Xylem also provides a leading portfolio of smart metering, network technologies and advanced analytics solutions for water, electric and gas utilities. In more than 150 countries, we have strong, long-standing relationships with customers who know us for our powerful combination of leading product brands and applications expertise with a strong focus on developing comprehensive, sustainable solutions.

For more information on how Xylem can help you, go to www.xylem.com.



Service and Returns:

Xylem Analytics Germany
Sales GmbH & Co. KG
WTW
Am Achalaich 11
82362 Weilheim
Germany

Tel.: +49 881 183-325

Fax: +49 881 183-414

E-Mail wtw.rma@xylem.com

Internet: www.xylemanalytics.com

xylem
Let's Solve Water

Xylem Analytics Germany GmbH
Am Achalaich 11
82362 Weilheim
Germany

