

TriOxmatic[®] 700 IQ F

DIQ/S 181 - D. O. SENSOR



a xylem brand



For the most recent version of the manual, please visit www.WTW.com.

Copyright

© Weilheim 2015, WTW GmbH
Reproduction in whole - or even in part - is prohibited without the
express written permission of WTW GmbH, Weilheim.
Printed in Germany.

TriOxmatic® 700 IQ F - Contents

1	Overview	5
1.1	Structure of the TriOxmatic® 700 IQ F	5
1.2	Recommended fields of application	5
2	Safety	6
2.1	Safety information	6
2.1.1	Safety information in the operating manual	6
2.1.2	Safety signs on the product	6
2.1.3	Further documents providing safety information	6
2.2	Safe operation	7
2.2.1	Authorized use	7
2.2.2	Requirements for safe operation	7
2.2.3	Unauthorized use	7
3	Commissioning	8
3.1	Scope of delivery	8
3.2	Installation	8
3.3	Commissioning / Getting the sensor ready for measurement	8
3.4	Setting table for the TriOxmatic® 700 IQ F	9
4	Measurement / operation	12
4.1	Measuring	12
4.2	Calibration	12
4.2.1	General information on calibration	12
4.2.2	Calibration in water vapor-saturated air	13
4.2.3	Reactivating a valid calibration	15
4.3	Function check	15
5	Maintenance, cleaning, disposal, and replacement	18
5.1	General maintenance notes	18
5.2	Cleaning the sensor shaft and membrane	18
5.3	Exchanging the electrolyte and membrane cap	21
5.4	Cleaning the electrodes	24
5.4.1	Cleaning the gold working electrode	26
5.4.2	Cleaning the silver counter electrode	27
5.5	Checking the sensor for freedom from zero-current	33
5.6	Storage	34

5.7	Disposal	34
5.8	Maintenance equipment and replacement parts	35
6	What to do if...	36
7	Technical data	38
7.1	Measuring characteristics	38
7.2	Application characteristics	39
7.3	General data	39
7.4	Electrical data	40
7.5	Characteristic data on delivery	40
8	Indexes	41
8.1	Explanation of the messages	41
8.1.1	Error messages	41
8.1.2	Informative messages	42

1 Overview

1.1 Structure of the TriOxmatic® 700 IQ F

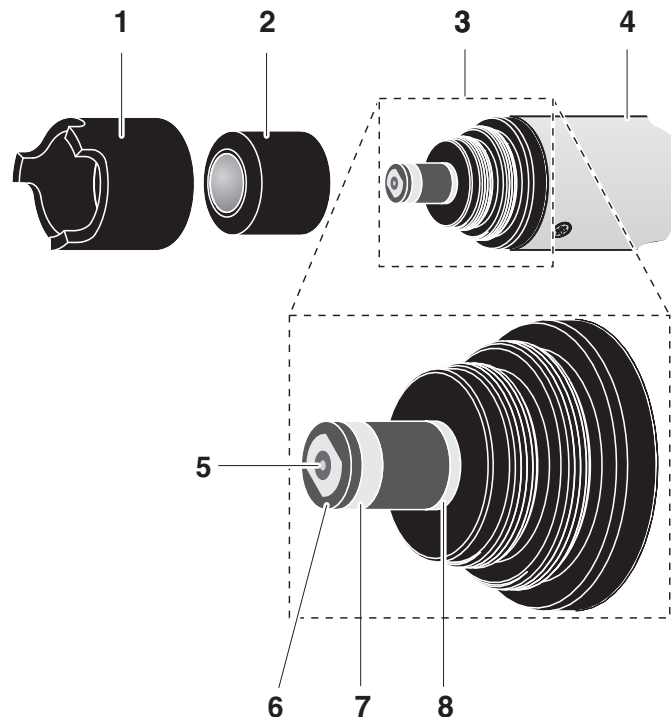

Fig. 1-1 Structure of the D.O. sensor

1	Protective hood
2	WP 600 membrane head
3	Electrode unit
4	Shaft
Electrode unit:	
5	Gold working electrode (cathode)
6	Insulator
7	Silver counter electrode (anode)
8	Reference electrode

1.2 Recommended fields of application

TriOxmatic® 700 IQ F

Stationary measurements in water/wastewater applications.

2 Safety

2.1 Safety information

2.1.1 Safety information in the operating manual

This operating manual provides important information on the safe operation of the product. Read this operating manual thoroughly and make yourself familiar with the product before putting it into operation or working with it. The operating manual must be kept in the vicinity of the product so you can always find the information you need.

Important safety instructions are highlighted in this operating manual. They are indicated by the warning symbol (triangle) in the left column. The signal word (e.g. "CAUTION") indicates the level of danger:



WARNING

indicates a possibly dangerous situation that can lead to serious (irreversible) injury or death if the safety instruction is not followed.



CAUTION

indicates a possibly dangerous situation that can lead to slight (reversible) injury if the safety instruction is not followed.

NOTE

indicates a situation where goods might be damaged if the actions mentioned are not taken.

2.1.2 Safety signs on the product

Note all labels, information signs and safety symbols on the product. A warning symbol (triangle) without text refers to safety information in this operating manual.

2.1.3 Further documents providing safety information

The following documents provide additional information, which you should observe for your safety when working with the measuring system:

- Operating manuals of other components of the measuring system (DIQ/S 181, accessories)
- Safety datasheets of calibration and maintenance equipment (e.g. cleaning solutions).

2.2 Safe operation

2.2.1 Authorized use

The authorized use of the TriOxmatic® 700 IQ F consists of its use as a sensor in the DIQ/S 181. Only the operation and running of the sensor according to the instructions and technical specifications given in this operating manual is authorized (see chapter 7 TECHNICAL DATA). Any other use is considered unauthorized.

2.2.2 Requirements for safe operation

Note the following points for safe operation:

- The product may only be operated according to the authorized use specified above.
- The product may only be supplied with power by the energy sources mentioned in this operating manual.
- The product may only be operated under the environmental conditions mentioned in this operating manual.
- The product may not be opened.

2.2.3 Unauthorized use

The product must not be put into operation if:

- it is visibly damaged (e.g. after being transported)
- it was stored under adverse conditions for a lengthy period of time (storing conditions, see chapter 7 TECHNICAL DATA).

3 Commissioning

3.1 Scope of delivery

- TriOxmatic® 700 IQ F
- ZBK 600 accessory kit
- The sensor is filled with electrolyte and provided with a protective hood and protective cap.
- Operating manual.

3.2 Installation

Connection cable



How to connect the sensor connection cable to the terminal strip of the DIQ/S 181 is described in chapter 3 INSTALLATION of the DIQ/S 181 operating manual



Do not suspend the sensor on the sensor connection cable. Use a sensor holder or armature. Information on this and other DIQ/S 181 accessories is given in the WTW catalog and on the Internet.

Minimum approach flow

The minimum required approach flow at the sensor must be present during measurement (see chapter 7 TECHNICAL DATA). The minimum approach flow can, e.g. be present due to:

- natural movement of the water (flow rate, sea disturbance)
- turbulences in the activated sludge basin.

3.3 Commissioning / Getting the sensor ready for measurement



1	Pull the protective cap off the protective hood of the sensor.
2	Leave the sensor to lie in the air for at least 60 minutes while it is switched on (polarization).



For the sensor to polarize, the following conditions must be fulfilled:

- The sensor is connected to the DIQ/S 181 with the sensor cable
- The DIQ/S 181 is in operation
- The sensor was identified by the DIQ/S 181.

3	If required, assign a user-defined name to the sensor (see DIQ/S 181 operating manual).
4	Set up the sensor (see section 3.4).
5	Calibrate the sensor (see section 4.2 CALIBRATION).

Precision measurements

Recommendation: In order to carry out precision measurements, leave the sensor to polarize for a longer period of time, e.g. overnight, and recalibrate it the following day.

3.4 Setting table for the TriOxmatic® 700 IQ F

Carrying out settings

Using <S>, switch from the measured value display to the main menu of the settings. Then navigate to the setting menu (setting table) of the sensor. The procedure is described in detail in the DIQ/S 181 operating manual.

Setting	Selection/values	Explanation
<i>Measuring mode</i>	<ul style="list-style-type: none"> ● <i>Concentration</i> ● <i>Saturation</i> 	Unit of the measured value in the measured value display.
<i>Measuring range Concentration</i>	<ul style="list-style-type: none"> ● <i>0 ... 60.0 mg/l</i> ● <i>0 ... 60.0 ppm</i> 	These measuring ranges are available for selection.
<i>Measuring range Saturation</i>	<ul style="list-style-type: none"> ● <i>0 ... 600 %</i> 	The measuring range is permanently set.

Setting	Selection/values	Explanation
<i>Calibration</i>	<ul style="list-style-type: none"> ● <i>valid</i> ● <i>invalid</i> ● <i>last valid</i> ● <i>active</i> ● <i>abort</i> 	<p>Displays and specifies which calibration data the measured value calculation will be based on.</p> <p><i>valid</i> indicates that a valid calibration is available. The value cannot be changed.</p> <p><i>invalid</i> is displayed if the last calibration is invalid and the sensor is blocked for measurement. In this case you can change the value to <i>last valid</i>, provided there is a valid calibration stored in the sensor. This is used to activate with the next exit from the setting table with <i>Save and quit</i> the last valid calibration stored in the sensor. Next time the setting table is opened, <i>valid</i> is displayed.</p> <p><i>active</i> indicates that the sensor is being calibrated. If <i>abort</i> is selected, the active calibration is canceled the next time the setting table is quit with <i>Save and quit</i>.</p>
<i>Temperature mode</i>	<ul style="list-style-type: none"> ● °C ● °F 	Unit of the measured temperature value (Celsius, Fahrenheit).
<i>Salinity</i> <i>Salinity input</i> (only with <i>Salinity = On</i>)	<ul style="list-style-type: none"> ● <i>On</i> ● <i>Off</i> 2.0 ... 70.0	<p>Determines whether the entered salinity should be taken into account.</p> <p>The entry of the salinity enables a salt content correction that compensates for the effect of salt contents > 0.1 % on the oxygen measurement.</p> <p>The salt content correction is recommended for measurements in salt-contaminated wastewater (salinity ≥ 2.0 corresponding to a conductivity of ≥ 3.4 mS/cm at a reference temperature $T_{REF} = 20\text{ °C}$).</p>

Setting	Selection/values	Explanation
<i>Temp. adjustment</i>	<i>-1.5 K ... +1.5 K</i>	<p>The temperature compensation enables the tolerances of the temperature sensor to be balanced (shifting of the zero point by $\pm 1.5\text{K}$).</p> <p>Notes:</p> <ul style="list-style-type: none"> ● Due to the thermal capacity of the sensor, it is necessary to place it in a container with at least 2 liters of water. ● Leave the sensor in this container for at least 15 minutes while stirring occasionally until the balancing can be performed. <p>With temperature differences between the water and sensor $> 10\text{ }^{\circ}\text{C}$, leave the sensor for at least 1 hour in this container while stirring occasionally until the balancing can be performed.</p>
<i>Save and quit</i>		<p>The settings are stored.</p> <p>The display switches to the next higher level.</p>
<i>Quit</i>		<p>The settings are not stored.</p> <p>The display switches to the next higher level.</p>

4 Measurement / operation

4.1 Measuring



CAUTION

Contact with the sample can lead to danger to the user! Depending on the type of sample, suitable protective measures must be taken (protective clothing, protective goggles, etc.).

For measuring submerge the operable sensor in the test sample. The measured value is available immediately on submersing.

4.2 Calibration

4.2.1 General information on calibration

Why calibrate?

During the operation of a D.O. sensor, the slope of the D.O. sensor changes with time. The calibration procedure determines the current slope of the sensor.

When to calibrate?

Calibrate before measuring and at regular intervals (depending on the application).

Calibration procedures

Ideally, calibration takes place in water vapor-saturated air. To do so, position the sensor approx. 2 cm above a water surface, for example in a narrow bucket or similar container with water.

In the case of air temperatures under 5 °C we recommend to calibrate not in air but in air-saturated water that has a higher temperature. You obtain air-saturated water by pouring water several times in and out of two vessels so that it sparkles.



For calibration the membrane always has to be clean, for calibration in air it has to be dry. Clean contaminated sensors before calibration (see section 5.2 CLEANING THE SENSOR SHAFT AND MEMBRANE).

Calibration record / calibration history

The result of the user calibration is stored in the calibration protocol and can be viewed afterwards (see DIQ/S 181 operating manual).

Maintenance condition

During calibration the sensor is in the so-called maintenance condition. All linked outputs remain in their current status. After finishing calibration the maintenance condition has to be switched off manually. More detailed information on the maintenance condition is given in the DIQ/S 181 operating manual.

4.2.2 Calibration in water vapor-saturated air

1	Switch to the measured value display with <M> .
2	Call up calibration with <C> . The next step switches on the maintenance condition for the sensor. A message on this appears on the display.
3	Confirm the message with <OK> . The maintenance condition is active. The menu-guided calibration routine starts. Follow the instructions on the display.
4	If necessary, clean the sensor and membrane and dry the membrane (see section 5.2 CLEANING THE SENSOR SHAFT AND MEMBRANE).
5	Start calibration and follow the instruction on the display until the instruction <i>Bring sensor into calibrating position</i> appears.

Calibrating position

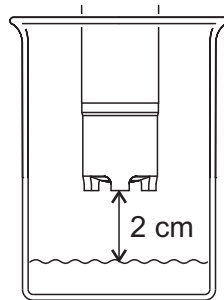

6	Bring the sensor into the calibrating position. To do so, position the sensor approx. 2 cm above a water surface, best in a narrow bucket or similar container with water. When doing so, no liquid should be brought on the membrane.
---	--



Up to this point, you can break off the calibration procedure at any time with the **<ESC>** key. The old calibration data remain active. However, you have to switch off the maintenance condition in any case.

After starting the determination of calibration data with the **<OK>** key (step 4), you cannot break off the calibration procedure any more.

7	Continue with <OK> . The display shows the steps that have to be carried out after the calibration is finished.
---	---

8	<p>Continue with <OK>.</p> <p>The sensor starts the calibration. The display switches to the measured value display. The <i>CAL</i> indicator flashes instead of the main measured value. At the same time, the momentary relative slope flashes as the secondary measured value.</p> <p>The process ends automatically as soon as the measured values meet the criterion for the stability control. With a great temperature difference between the sensor and the environment this may take a while.</p> <p>Subsequently, the main measured value and temperature are displayed. The measured value flashes because the sensor is still in the maintenance condition.</p>
9	If the calibration was successful, immerse the sensor in the test sample.
10	Wait for a stable measured value.
11	Switch off the maintenance condition.



In the case of air temperatures under 5 °C do not calibrate the sensor in air but in air-saturated water that has a higher temperature. You obtain air-saturated water by pouring water several times in and out of two vessels so that it sparkles.

Then immerse the sensor in a vessel with air-saturated water (calibrating position) and calibrate as described above.

Possible calibration results

The calibration data are evaluated. A calibration procedure can have the following results:

Display after calibrating	Log book entries (meaning/actions)
Measured value display	Sensor was successfully calibrated. Calibration data see calibration history.
"----"	<p>Sensor could not be calibrated. Sensor blocked for measurement.</p> <ul style="list-style-type: none"> – Carry out maintenance activities immediately (see operating manual). – View the calibration history. – Check the calibration conditions and calibration standard.

4.2.3 Reactivating a valid calibration

The TriOxmatic® 700 IQ F provides a feature with which you can reactivate the last valid calibration if necessary. Thus you can immediately continue to measure if a calibration failed.



Reactivating old calibration data is a temporary measure. Take into consideration that the sensor may provide wrong measured values. Ensure the correct functioning of the sensor by checking and/or recalibrating it.

Reactivating the last valid calibration data

1	Open the setting table (see section 3.4).
2	In the <i>Calibration</i> menu item, select the <i>last valid</i> setting and then quit the setting table with <i>Save and quit</i> .

4.3 Function check

The function check is the simplest way of letting you know whether the sensor needs to be cleaned and calibrated.



The function check can either be performed in water vapor-saturated air or in air-saturated water. In the case of air temperatures under 5 °C we recommend to perform the function check not in air but in air-saturated water that has a higher temperature.



The function check is carried out in the measuring mode, % saturation. When switching to the measuring mode % saturation, information on linked outputs is lost.

Function check in water vapor-saturated air

Proceed as follows:

1	Switch to the measured value display with <M> .
2	Call up calibration with <C> . The next step switches on the maintenance condition for the sensor. A message on this appears on the display.
3	Confirm the message with <OK> . The maintenance condition is active. The menu-guided calibration routine starts. Follow the instructions on the display.

- 4 | If necessary, clean the sensor and membrane and dry the membrane (see section 5.2 CLEANING THE SENSOR SHAFT AND MEMBRANE).
- 5 | Take the sensor out of the measuring solution and position it approx. 2 cm above a water surface, best in a narrow bucket or similar container with water. When doing so, no liquid should be brought on the membrane.

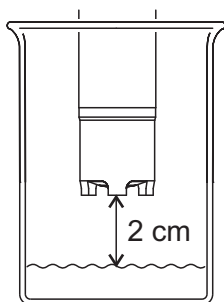

- 6 | Wait at least 15 minutes for the temperature to adapt.
- 7 | In the sensor setting table, select the measuring mode *Saturation* (unit %) and switch to the measured value display with <M>.
- 8 | Read the measured value and determine whether it lies within the range of precision required by the user.



If there are large temperature differences between the sample and the air above the surface of the water, a balancing period of more than 15 minutes may be required.

Measured values within the required precision

If the measured value lies within the range of precision required by the user, no cleaning or recalibration is necessary.

Example:

Required precision 5 %.

Measured value in air: 97 % saturation (nominal value: 100%)

No cleaning or recalibration is necessary as the measurement error lies within the range of precision required by the user.

Measured values outside the required precision

If the measured value lies outside the range of precision required by the user, clean the sensor shaft and membrane (see section 5.2) and calibrate the sensor (see section 4.2).



In the case of air temperatures under 5 °C do not perform the function check in air but in air-saturated water that has a higher temperature. You obtain air-saturated water by pouring water several times in and out of two vessels so that it sparkles.

Then submerge the sensor in a vessel with air-saturated water and perform the function check as described above.

5 Maintenance, cleaning, disposal, and replacement

5.1 General maintenance notes



CAUTION

Contact with the sample can lead to danger to the user! Depending on the type of sample, suitable protective measures must be taken (protective clothing, protective goggles, etc.).

Maintenance condition

We recommend switching on the maintenance condition each time before removing the sensor from its measuring position. This avoids any unintended reactions of the linked outputs. More detailed information on the maintenance condition is given in the DIQ/S 181 operating manual.

5.2 Cleaning the sensor shaft and membrane

For normal operation (e.g. municipal wastewater), cleaning and calibration are strongly recommended:

- if there is any pollution (according to visual check)
- if the measured values are suspected of being incorrect (usually too low)
- if the measured value lies outside the range of precision required by the user during the function check.

Cleaning agents

Contamination	Cleaning agents
Slurry and loosely adhering dirt or biological films	Soft cloth or soft sponge, warm tap water with detergent
Salt and / or lime deposits	Acetic acid (volume percentage = 20 %), soft cloth or soft sponge

Cleaning

1	Pull the sensor out of the sample.
2	Get rid of any coarse contamination on the sensor (e.g. brush it off in a bucket of tap water, wash it down with a hose or wash it off with a cloth).
3	Unscrew the protective hood from the sensor.

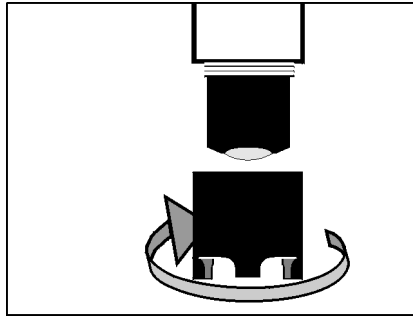
**CAUTION**

Acetic acid irritates the eyes and the skin. When handling acetic acid, always wear protective gloves and protective goggles.

NOTE

Clean the membrane very carefully!

Make sure the membrane is not damaged, e.g. by sharp-edged objects, by laying it on sharp stones, etc.

- 4 **Carefully** clean the sensor shaft and membrane as specified in the CLEANING AGENTS section.

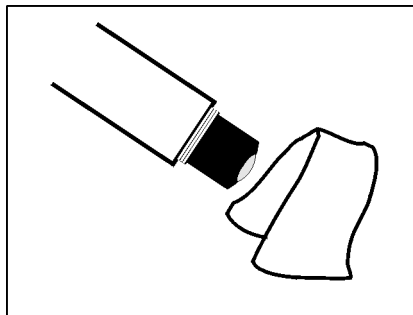

- 5 Then, rinse it thoroughly with tap water.

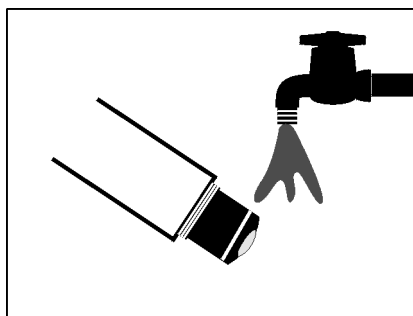

- 6 Also clean and rinse the protective hood.

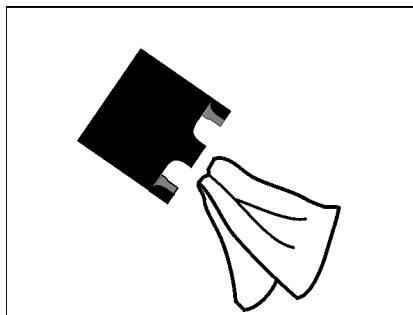

- 7 Screw the protective hood back on again.

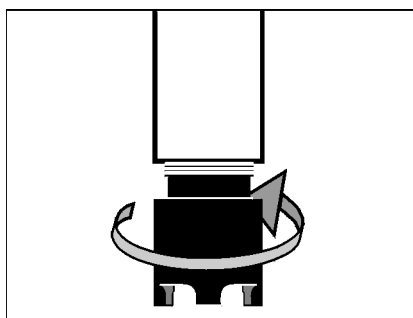

- 8 If necessary, carefully dry the membrane with a lint-free paper towel.

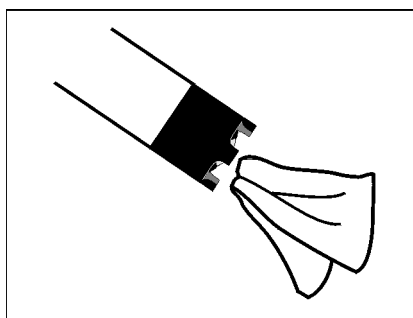

- 9 Recalibrate the sensor (see section 4.2 CALIBRATION).

5.3 Exchanging the electrolyte and membrane cap

WTW delivers the sensor ready for operation. The electrolyte solution and membrane head must only be replaced:

- if the membrane is heavily contaminated and a calibration error occurs (log book message)
- if the membrane is damaged (log book message)
- if the electrolyte solution is depleted or the counter electrode is poisoned (log book message)
- after the gold working electrode and the silver counter electrode have been cleaned



Information on the contents and structure of the log book and how to call it up is given in the chapter LOG BOOK of the DIQ/S 181 operating manual.



Only unscrew the membrane head for maintenance purposes. After doing so, always use a new membrane head!

Change the electrolyte and membrane cap

1	Pull the sensor out of the sample.
2	Get rid of any coarse contamination on the sensor (e.g. brush it off in a bucket of tap water, wash it down with a hose or wash it off with a cloth).
3	Unscrew the protective hood from the sensor.



CAUTION

The ELY/A electrolyte solution irritates eyes, skin and mucus membranes. If it comes into contact with the eyes, rinse thoroughly with water and consult a doctor! During working activities, always wear suitable protective gloves and protective goggles/face shield! Follow the safety datasheet.

4	Unscrew the membrane cap (for disposal of membrane cap and electrolyte solution, see section 5.7).
---	--

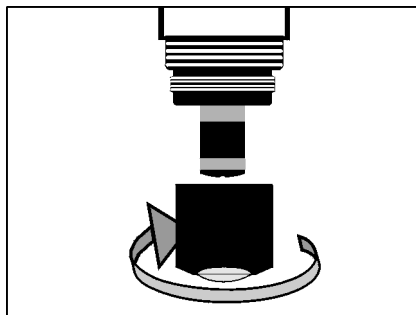

5 Rinse the sensor head with tap water.

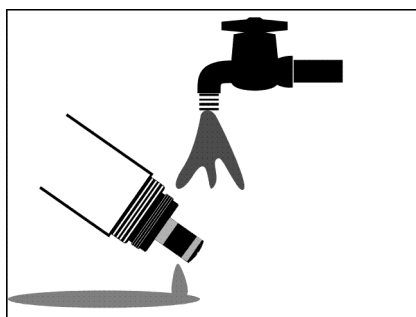

6 Carefully rub the silver counter electrode with a paper towel and rinse it with deionized water.

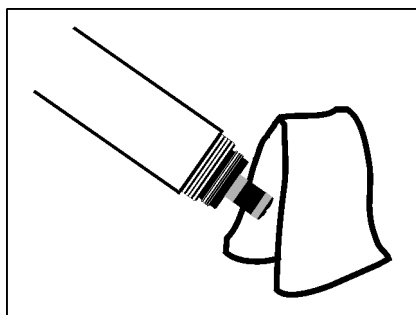

7 Thoroughly rinse the sensor head with electrolyte solution.

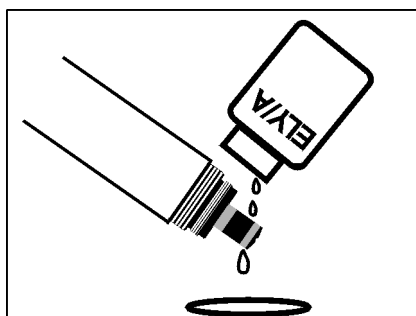

- 8 Fill a new WP 600 membrane cap with ELY/A electrolyte solution (see section 5.8 MAINTENANCE EQUIPMENT AND REPLACEMENT PARTS).

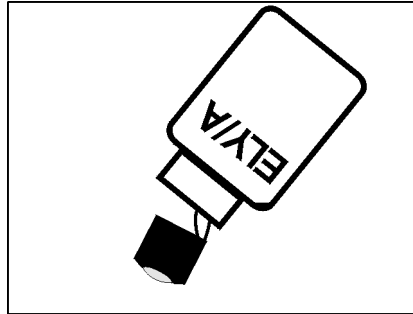

- 9 Throw away the first filling and fill the membrane head once more with electrolyte solution.

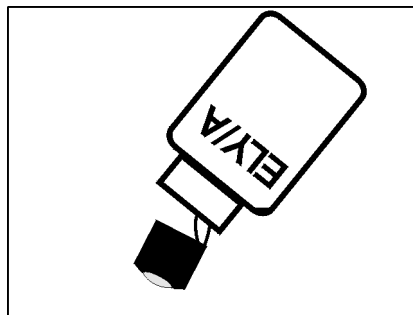

- 10 Remove any air bubbles by carefully tapping the membrane head.

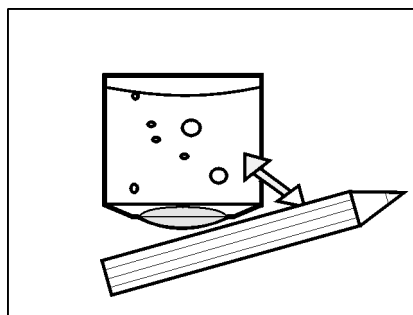

CAUTION

The ELY/A electrolyte solution irritates eyes, skin and mucus membranes. If it comes into contact with the eyes, rinse thoroughly with water and consult a doctor! During working activities, always wear suitable protective gloves and protective goggles/face shield! Follow the safety datasheet.

- | | |
|----|---|
| 11 | Screw the membrane head onto the shaft while holding the sensor at an angle. Excess electrolyte solution is forced out of the ventilation area. |
|----|---|

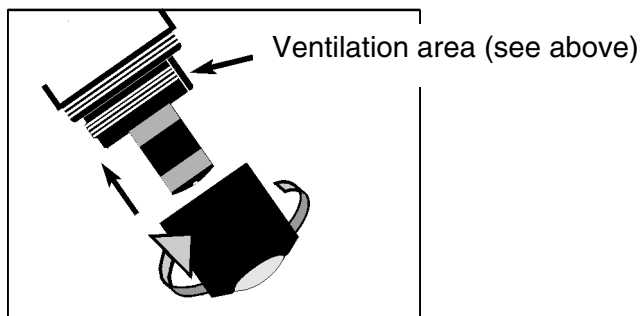

- | | |
|----|---|
| 12 | The filling should be free of air bubbles as far as possible. However, small air bubbles do not cause any interference. |
| 13 | After approx. 60 minutes polarization time, the sensor is ready for operation. |
| 14 | Recalibrate the sensor (see section 4.2 CALIBRATION). |



Precision measurements

Recommendation: In order to carry out precision measurements, leave the sensor to polarize for a longer period of time, e.g. overnight, and recalibrate it the following day.



In the following cases, you must refill the sensor once more:

- if there are large air bubbles
- if there are air bubbles on the gold working electrode
- for measurements at high water pressure, even if small air bubbles are present. Otherwise, the membrane and, as a result, the measuring characteristics could change.
- if the sensor cannot be calibrated.

5.4 Cleaning the electrodes

The counter electrode and reference electrode always exhibit a distinct coloration. This is necessary for the operation of the sensor. This is not contamination. Cleaning is only required in cases of slopes that are too small or too large (the sensor cannot then be calibrated) that cannot be resolved by changing the membrane head and the electrolyte solution.

NOTE

Prior to cleaning the electrodes, disconnect the DIQ/S 181 from the power supply. Otherwise, undesirable electrochemical reactions can occur that may lead to the destruction of the sensor.

Preparatory activities

1	Pull the sensor out of the sample and remove any coarse contamination from the sensor (e.g. brush it off in a bucket of tap-water, wash it down with a hose or wash it off with a cloth).
2	Disconnect the DIQ/S 181 from the power supply.
3	Unscrew the protective hood from the sensor.

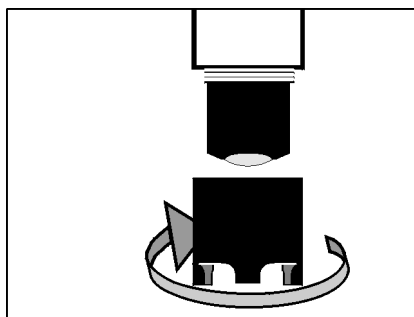
**CAUTION**

The ELY/A electrolyte solution irritates eyes, skin and mucus membranes. If it comes into contact with the eyes, rinse thoroughly with water and consult a doctor! During working activities, always wear suitable protective gloves and protective goggles/face shield! Follow the safety datasheet.

4	Unscrew the membrane cap (for disposal of membrane cap and electrolyte solution, see section 5.7).
---	--

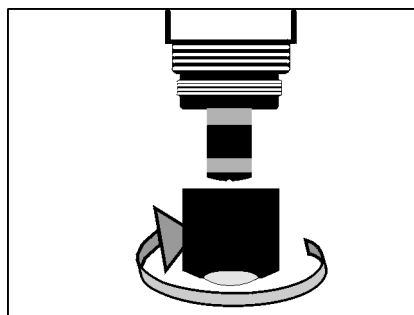

5	Rinse the sensor head with tap water.
---	---------------------------------------

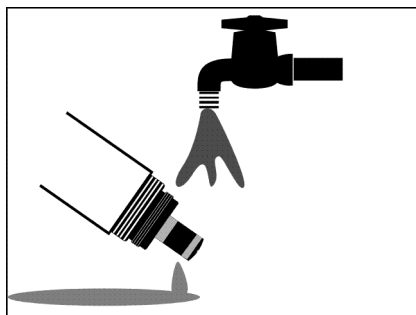

5.4.1 Cleaning the gold working electrode

- 1 Moisten the gold working electrode and the SF 300 polishing strip (see section 5.8 MAINTENANCE EQUIPMENT AND REPLACEMENT PARTS) with deionized water.
- 2 Using the rough side of the **wet** SF 300 polishing strip, polish off any contamination from the gold working electrode using light pressure.

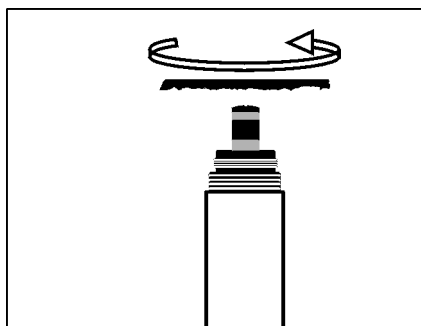

NOTE

Do not use any conventional sandpaper or glass-fiber brushes. They could damage the electrode.

- 3 Rinse the sensor head with deionized water.

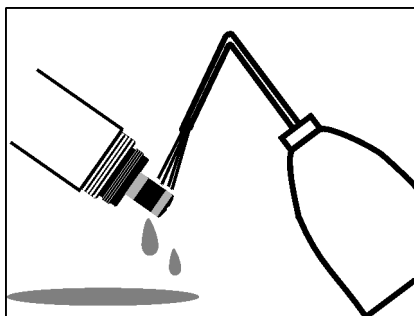

Cleaning the gold working electrode may already be sufficient to enable the sensor to be calibrated again. For safety, however, we recommend to also clean the silver counter electrode (see section 5.4.2) and to use a new membrane cap afterwards.

5.4.2 Cleaning the silver counter electrode

We recommend to clean the silver counter electrode with the RA 600 cleaning attachment that is available as an accessory (see section 5.8 MAINTENANCE EQUIPMENT AND REPLACEMENT PARTS). This avoids the reference electrode coming into contact with the cleaning solution. However, it is also possible to clean the silver counter electrode in a beaker.

NOTE

The reference electrode must not come into contact with the cleaning solution under any circumstances. This could destroy the reference electrode and cause the sensor to become defective. However, no danger can arise if the RA 600 is used correctly.

Cleaning the silver counterelectrode with the RA 600 cleaning attachment

- 1 Wipe the silver counter electrode with a lint-free paper towel and carefully remove any loose deposits.

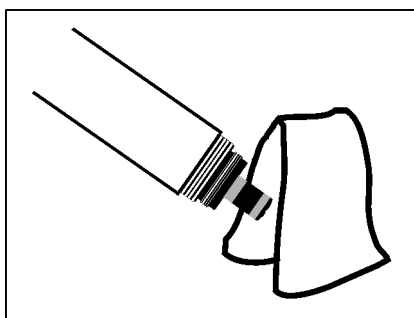

- 2 | Screw the cleaning attachment onto the sensor, instead of the membrane head.

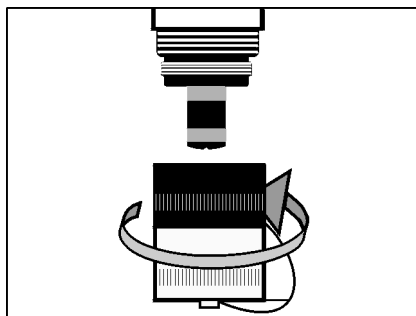
**NOTE**

Never grease or lubricate the inner O-ring in the RA 600 cleaning attachment!

- 3 | Remove the screw cap from the safety cap of the cleaning attachment.

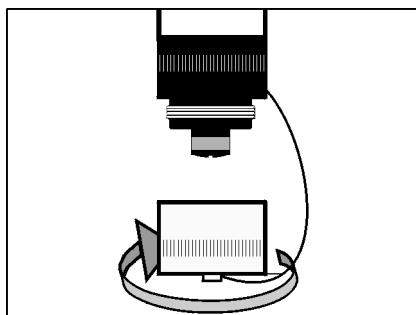

- 4 | Fill the screw cap with RL-AG/Oxi cleaning solution (see section 5.8 MAINTENANCE EQUIPMENT AND REPLACEMENT PARTS).

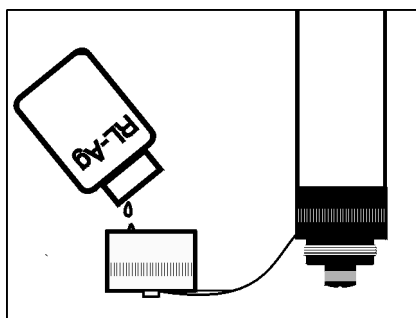

- 5 | Screw the sensor with the safety cap onto the screw cap.

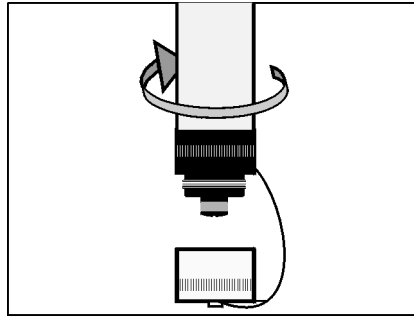

6 | Leave the cleaning solution to take effect for a maximum of 1 hour.

7 | Unscrew the screw cap.

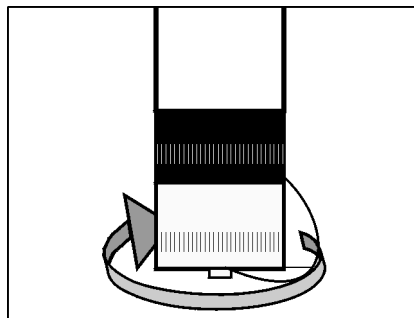

8 | Thoroughly rinse the electrode unit with the safety cap on with deionized water.

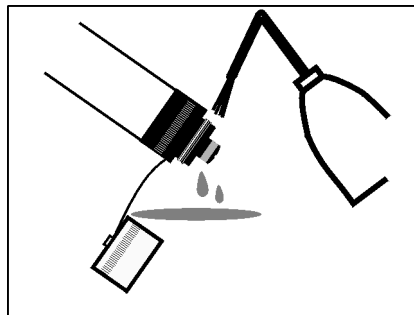

9 | Unscrew the safety cap.

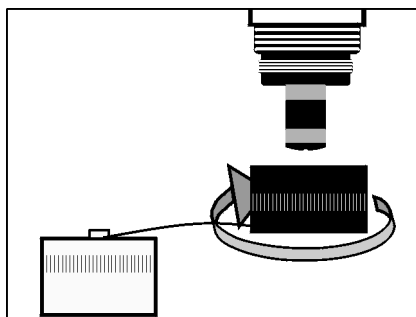

10 | Rinse the sensor head and the electrode unit several times with deionized water.

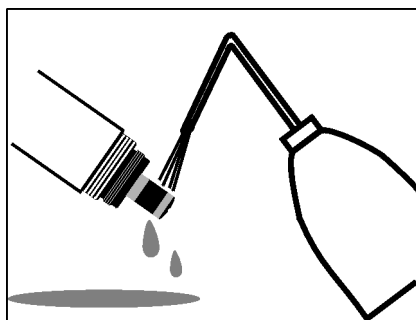

11 | Rinse the sensor head and the electrode unit for at least an hour in deionized water.

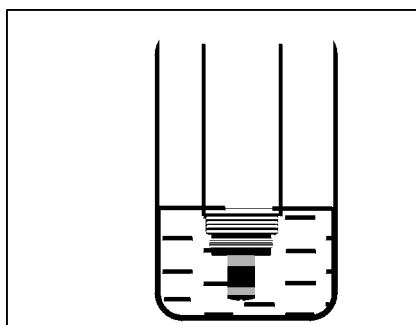

12 | Carefully shake off the drops of water.

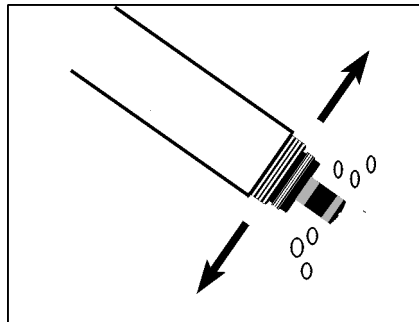

- | | |
|----|---|
| 13 | Fill a new WP 600 membrane cap and screw it on (see section 5.3 EXCHANGING THE ELECTROLYTE AND MEMBRANE CAP). |
| 14 | Reconnect the DIQ/S 181 with the power supply. |
| 15 | Leave the sensor to lie in the air for at least 60 minutes while it is switched on (polarization).
The sensor is ready to operate. |
| 16 | Recalibrate the sensor (see section 4.2 CALIBRATION). |



Cleaning the silver counterelectrode in a beaker

- | | |
|---|---|
| 1 | Wipe the silver counter electrode with a lint-free paper towel and carefully remove any loose deposits. |
|---|---|

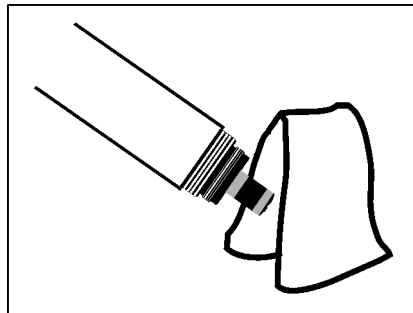

- | | |
|---|---|
| 2 | Fill a beaker (150 ml, high-sided form) with approx. 25 ml RL-AG/Oxi cleaning solution. |
|---|---|

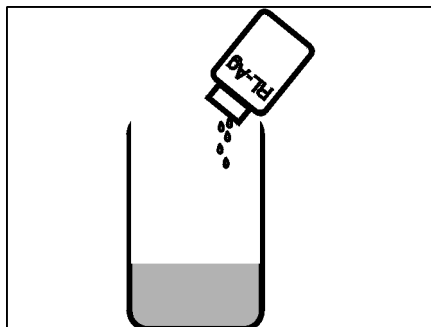
**NOTE**

The reference electrode must not come into contact with the cleaning solution under any circumstances. This could destroy the reference electrode and cause the sensor to become defective.

- 3 Clamp the sensor in a stand.
Submerge the electrode unit in the RL-AG/Oxi cleaning solution to just above the silver counter electrode.

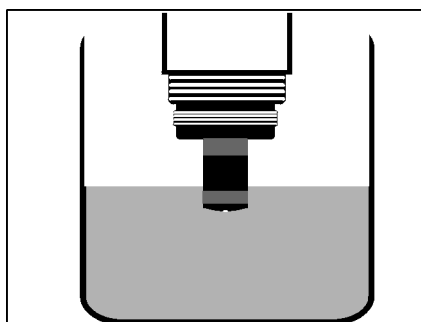

- 4 Leave the cleaning solution to work for 1 hour.
- 5 Rinse the sensor head and the electrode unit several times with deionized water.

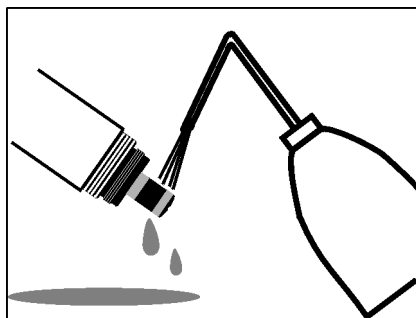



- 6 Rinse the sensor head and the electrode unit for at least an hour in deionized water.

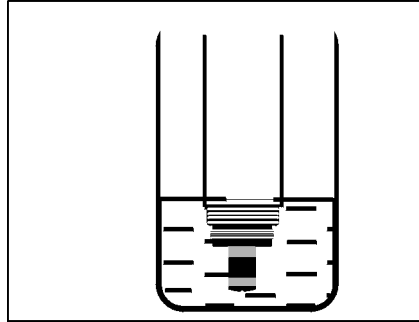

- 7 Carefully shake off the drops of water.

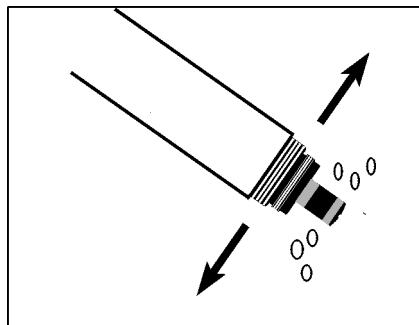

- 8 Fill a new WP 600 membrane cap and screw it on (see section 5.3 EXCHANGING THE ELECTROLYTE AND MEMBRANE CAP).

- 9 Reconnect the DIQ/S 181 with the power supply.

- 10 Leave the sensor to lie in the air for at least 60 minutes while it is switched on (polarization).
The sensor is ready to operate.



- 11 Recalibrate the sensor (see section 4.2 CALIBRATION).

5.5 Checking the sensor for freedom from zero-current

The sensor is zero-current free. Therefore, no calibration of the sensor in an oxygen-free solution is included.

However, it is possible to check the freedom from zero-current according to DIN EN 25814/ISO 5814. This is advisable if there is any suspicion of a malfunction.

Test solution

1 g/l aqueous sodium sulfite solution, Na₂SO₃ (addition of 1 mg/l of a cobalt(II) salt accelerates the removal of oxygen from the solution.)



The sensor should be in operation for at least 1 hour before the inspection.

Test procedure

- | | |
|---|--|
| 1 | Clean the sensor (see section 5.2 CLEANING THE SENSOR SHAFT AND MEMBRANE). |
|---|--|



All links are erased when the measuring mode is changed.

- | | |
|---|---|
| 2 | In the sensor setting table, select the measuring mode <i>Sättigung</i> (unit %) and switch to the measured value display with <M>. |
| 3 | Submerge the sensor in the test solution. |
| 4 | Leave the sensor in the test solution for an hour. |
| 5 | Read the measured value. |

**Test criterion**

The sensor is OK if < 2 % oxygen saturation is displayed as the measured value.

If the measured value is > 2 %:

- Clean the gold working electrode (see section 5.4.1 CLEANING THE GOLD WORKING ELECTRODE) and change the electrolyte and membrane cap (see section 5.3 EXCHANGING THE ELECTROLYTE AND MEMBRANE CAP).
- If necessary, also clean the silver counter electrode (see section 5.4.2 CLEANING THE SILVER COUNTER ELECTRODE).

5.6 Storage

Store the clean and dry sensor with its protective cap in place. Observe the allowed temperature range (see chapter 7 TECHNICAL DATA); the sensor may be stored in any position.

5.7 Disposal

We recommend disposing of the sensor without the membrane head as electronic refuse.

**CAUTION**

The ELY/A electrolyte solution irritates eyes, skin and mucus membranes. If it comes into contact with the eyes, rinse thoroughly with water and consult a doctor! During working activities, always wear suitable protective gloves and protective goggles/face shield! Follow the safety datasheet.

Disposal of the membrane cap

1	Before disposing of the membrane head, unscrew it and rinse with water.
2	Dispose of the membrane head in the household refuse.



To dispose of the chemicals, follow the relevant safety datasheets. The safety datasheets can be obtained from WTW.

5.8 Maintenance equipment and replacement parts

Description	Model	Order no.
Accessory case (2 replacement membrane heads, 50 ml electrolyte solution, 50 ml cleaning solution, polishing film)	ZBK 600	202 620
Replacement membrane caps (2 pieces)	WP 600/2	202 850
Electrolyte solution (1 bottle x 50 ml)	ELY/A	205 212
Cleaning solution for silver counter electrode (1 bottle x 50 ml)	RL-Ag/Oxi	205 200
Polishing film	SF 300	203 680
Cleaning attachment for cleaning the counterelectrode	RA 600	202 510

6 What to do if...

The sensor is in the air and the display shows 0.0 mg/l or 0% O₂	Cause	Remedy
	No electrolyte in the membrane head	Change the WP 600 membrane cap (see section 5.3)
The sensor cannot be calibrated	Cause	Remedy
	Contaminated membrane head	<ul style="list-style-type: none"> – Clean the outside of the sensor (according to operating manual), wait at least 15 minutes and recalibrate it. – In the case of contamination that cannot be removed: Change the membrane head and electrolyte
If the sensor still cannot be calibrated after changing the electrolyte and membrane head	Cause	Remedy
	Contaminated electrodes or sensor toxification	Clean the electrodes (see section 5.4)
Mechanical damage to the sensor	Cause	Remedy
		Return the sensor
Measured values too low	Cause	Remedy
	Membrane contaminated	Clean the outside of the sensor, then recalibrate (see section 5.2 and section 4.2)
	Sensor has not been calibrated for a long time	
	Membrane does not fit snugly on the gold working electrode	Change the membrane cap, then recalibrate (see section 5.3 and section 4.2)

Measured value fluctuating heavily	Cause	Remedy
	Membrane head loose	Screw the membrane head tight
	Membrane does not fit snugly on the gold working electrode	Change the membrane cap, then recalibrate (see section 5.3 and section 4.2)
Measured values too high	Cause	Remedy
	Sensor not yet completely polarized	Wait for complete polarization (at least 1 hour)
	Sensor has not been calibrated for a long time	Clean the outside of the sensor, then recalibrate (section 5.2 and section 4.2)
Incorrect temperature display	Cause	Remedy
	Temperature sensor defective	Return the sensor
Measured value flashes	Cause	Remedy
	Maintenance condition is switched on	<ul style="list-style-type: none"> – If the maintenance condition was activated manually (e.g. by pressing the <C> key): Switch off the maintenance condition manually in the menu <i>PROPERTIES</i> (see DIQ/S 181 operating manual) – if the maintenance condition was switched on automatically (e.g. by the cleaning system): The maintenance condition will be terminated automatically

7 Technical data

7.1 Measuring characteristics

Measuring principle Membrane-covered amperometric sensor with potentiostatically operated 3-electrode system;
Integrated microprocessor electronics, shielded 2-wire connection for power and data transmission.

Electrolyte ELY/A

Measuring ranges and resolution

Measuring mode	Measuring range	Resolution
D. O. concentration	0.0 ... 60.0 mg/l 0.0 ... 60.0 ppm	0.1 mg/l 0.1 ppm
D. O. saturation	0 ... 600 % (\approx 0 ... 1200 mbar pO ₂)	1 %

Temperature compensation

IMT (integrated membrane temperature compensation)

Measurement in water

According to solubility function DIN 408 / Part 22

Measurement in salt-contaminated wastewater

Salinity input from 2.0 ... 70.0;
corresponds to 3.4 mS/cm ... 86.2 mS/cm at T_{REF} 20 °C
(salinity measurement in the range 2 ... 42 according to IOT = International Oceanographic Tables)

Polarization time

In the case of recommissioning or change of electrolyte	At least 60 minutes
In the case of short polarization interruptions (depending on the duration of the interruption)	15 to 60 minutes

Temperature measurement

Temperature sensor	Integrated NTC
Measuring range	- 5 °C ... + 60 °C (23 ... 140 °F)
Accuracy	\pm 0.5 K
Resolution	0.1 K

Calibration procedures

Air calibration

Air pressure compensation

Manual | By entering the air pressure or location altitude

7.2 Application characteristics

Allowed temperature range	Measuring medium	0 °C ... + 60 °C (32 ... 140 °F)
	Storage/transport	- 5 °C ... + 65 °C (23 ... 149 °F)
Allowed pH range of the measuring medium	4 ... 12	
Pressure resistance	Sensor with sensor cable:	
	Max. allowed overpressure	10 ⁵ Pa (1 bar)
	Max. allowed overpressure with installation in a pipe	10 ⁶ Pa (10 bar)
	The sensor meets all requirements according to article 3(3) of 97/23/EG ("pressure equipment directive").	
Type of protection	IP 68, 1 bar (10 ⁵ Pa)	
Depth of immersion	min. 10 cm; max. 10 m depth	
Operating position	Any, if the minimum approach flow is guaranteed	
Approach flow	≥ 5 cm/s (with 1 % measurement accuracy)	

7.3 General data

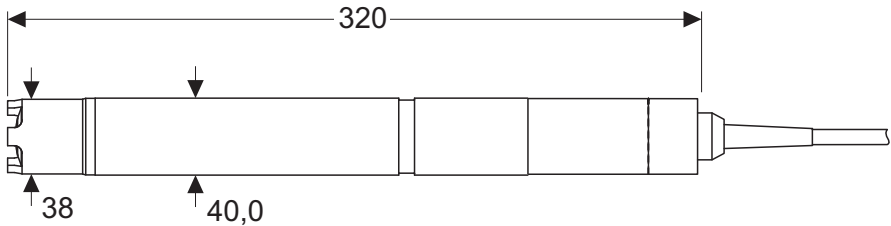
Dimensions		
Weight (with sensor connection cable)	TriOxmatic® 700 IQ F	Approx. 1000 g
Material	Shaft	V4A stainless steel 1.4571 *
	Membrane head	POM
	Membrane	ETFE, robust (thickness 50 µm)
	Sensor head	POM

Insulator	PEEK
Protective hood	POM

* Stainless steel can be corrodible if there are chloride concentrations of 500 mg/L or more.

Automatic sensor monitoring (SensCheck function)

SensReg	Electrolyte solution depleted
SensLeck	Membrane head leaking

Instrument safety

Applicable norms	<ul style="list-style-type: none"> – EN 61010-1 – UL 3111-1 – CAN/CSA C22.2 No. 1010.1
------------------	---

7.4 Electrical data

Nominal voltage	max. 24 VDC, via the DIQ/S 181 (for details see DIQ/S 181 operating manual, chapter Technical data)
Power consumption	0.2 W
Protective class	III

7.5 Characteristic data on delivery

Zero signal	< 0.2 % of the saturation value
Response time at 25 °C	t ₉₀ (90 % of the final value display after) < 180 s
Own consumption	0.0059 µg h ⁻¹ (mg/l) ⁻¹ at 20 °C
Drift	< 1 % per month during permanent polarization

Working life per electrolyte filling

D.O. concentration	Theoretical electrolyte reserve
Air saturation	approx. 5 years
< 2 mg/l	approx. 25 years

8 Indexes

8.1 Explanation of the messages

This chapter contains a list of all the message codes and related message texts for the TriOxmatic® 700 IQ F sensor.



Information on

- the contents and structure of the log book and
- the structure of the message code

See DIQ/S 181 operating manual, chapter LOG BOOK.

8.1.1 Error messages

Message code	Message text
EA1	<i>Meas. range exceeded or undercut</i> * <i>Check process</i> * <i>Select other meas. range</i>
EA2	<i>Sensor temperature too high!</i> * <i>Check process and application</i>
EA3	<i>Sensor temperature too low!</i> * <i>Check process and application</i>
EC4	<i>Sensor could not be calibrated, sensor blocked for measurement</i> <i>Cause: instable signal</i> * <i>Check polarization time and temperature adjustment</i> * <i>Check calibration conditions</i> * <i>Read calibration history</i> * <i>Repeat calibration, if unsuccessful: service the sensor (see operating manual)</i>
EC5	<i>Sensor could not be calibrated, sensor blocked for measurement</i> <i>Cause: slope error</i> * <i>Check polarization time and temperature adjustment</i> * <i>Check calibration conditions</i> * <i>Read calibration history</i> * <i>Repeat calibration, if unsuccessful: service the sensor (see operating manual)</i>

Message code	Message text
EI3	<i>Operational voltage too low</i> <i>* Check installation and cable lengths, Follow installation instructions</i> <i>* Power supply module overloaded</i> <i>* Check terminal and module connections</i> <i>* Defective component, replace components</i>
EI4	<i>Operational voltage too low, no operation possible</i> <i>* Check installation and cable lengths, Follow installation instructions</i> <i>* Power supply module overloaded</i> <i>* Check terminal and module connections</i> <i>* Defective component,</i> <i>replace components</i>
ES1	<i>Component hardware defective</i> <i>* Contact WTW</i>
ESB	<i>SensReg: Electrolyte supply is depleted</i> <i>* Change electrolyte solution and membrane head immediately (see operating manual)</i>
ESC	<i>SensLeck: Membrane head damaged</i> <i>* Change electrolyte solution and membrane head immediately (see operating manual)</i>

8.1.2 Informative messages

Message code	Message text
IC1	<i>Sensor has been successfully calibrated</i> <i>* For calibration data, see calibration history</i>
IC4	<i>Last valid calibration has been activated. Make sure the sensor operates correctly.</i>

Xylem |'zīləm|

- 1) The tissue in plants that brings water upward from the roots;
- 2) a leading global water technology company.

We're a global team unified in a common purpose: creating advanced technology solutions to the world's water challenges. Developing new technologies that will improve the way water is used, conserved, and re-used in the future is central to our work. Our products and services move, treat, analyze, monitor and return water to the environment, in public utility, industrial, residential and commercial building services settings. Xylem also provides a leading portfolio of smart metering, network technologies and advanced analytics solutions for water, electric and gas utilities. In more than 150 countries, we have strong, long-standing relationships with customers who know us for our powerful combination of leading product brands and applications expertise with a strong focus on developing comprehensive, sustainable solutions.

For more information on how Xylem can help you, go to www.xylem.com.



Service and Returns:

Xylem Analytics Germany
Sales GmbH & Co. KG
WTW
Am Achalaich 11
82362 Weilheim
Germany

Tel.: +49 881 183-325

Fax: +49 881 183-414

E-Mail wtw.rma@xylem.com

Internet: www.xylemanalytics.com

xylem
Let's Solve Water

Xylem Analytics Germany GmbH
Am Achalaich 11
82362 Weilheim
Germany

