

BEDIENUNGSANLEITUNG
OPERATING MANUAL
MODE D'EMPLOI
INSTRUCCIONES DE OPERACIÓN

ba77017defs01 10/2013

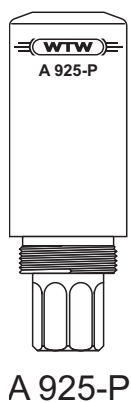

A 925-P
A 925-P/K
A 925-P/S

SCHUTZARMIERUNG FÜR IDS-FELDSENSOREN



a xylem brand

A 925-P(/x)

Bedienungsanleitung	1
Montage	3
Technische Daten	3
Weiteres Zubehör	3
Operating manual	5
Installation	7
Technical data	7
Further accessories	7
Mode d'emploi.....	9
Montage	11
Caractéristiques techniques	11
Autres accessoires	11
Instrucciones de operación	13
Montaje	15
Especificaciones técnicas	15
Otros accesorios	15

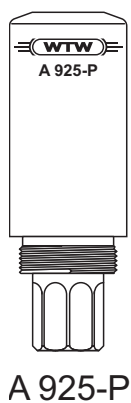

A 925-P/K
A 925-P/S

A 925-P

A 925-P/K

A 925-P/S

SCHUTZARMIERUNG FÜR IDS-FELDSENSOREN



a xylem brand



Bild 1



Bild 2

Montage

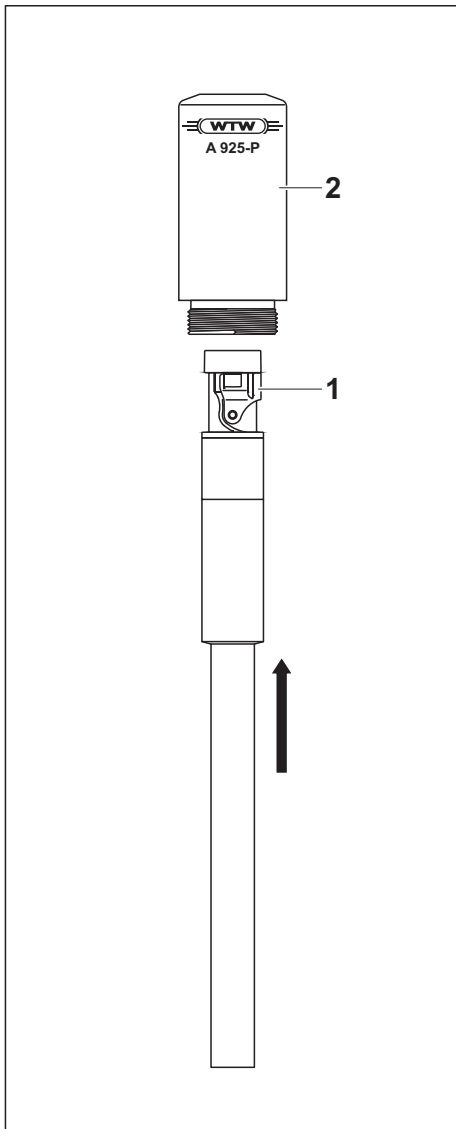
Sensoreinbau

1	Sensoranschlusskabel gegebenenfalls abstecken und Verriegelung (Pos. 1 in Bild 1) am Sensor vollständig einklappen.
2	Sensor in den Kopf (Pos. 2 in Bild 1) schieben.
3	Überwurfmutter (Pos. 3 in Bild 2) über Sensor schieben und von Hand in den Kopf hineinschrauben.
4	/K- und /S-Varianten: Schutzkorb (Pos. 4 in Bild 2) aufschrauben.

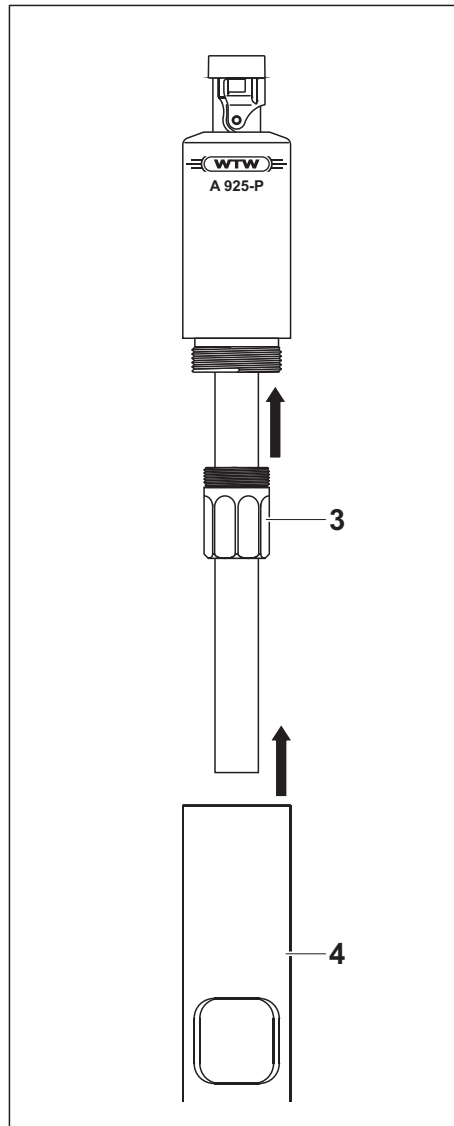
Technische Daten

Abmessungen

Durchmesser	38 mm
Längen:	
– A 925-P	107 mm
– A 925-P/x	235 mm

Materialien

Kopf	POM
Überwurfmutter	POM
Schutzkorb (/K- Varianten)	POM
Schutzkorb (/S- Varianten)	Edelstahl 1.4571

Weiteres Zubehör

Beschreibung	Modell	Best.-Nr.
Schutzdeckel für Schutzkorb (/K- und /S-Varianten)	SK-325	201 580

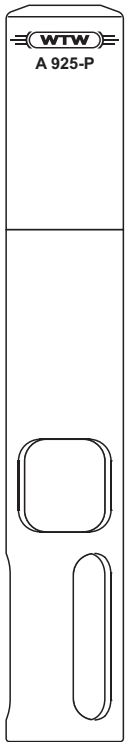
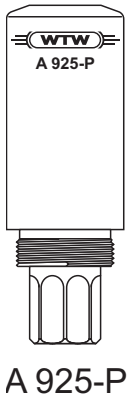

A 925-P
A 925-P/K
A 925-P/S

PROTECTIVE ARMORING FOR IDS FIELD SENSORS

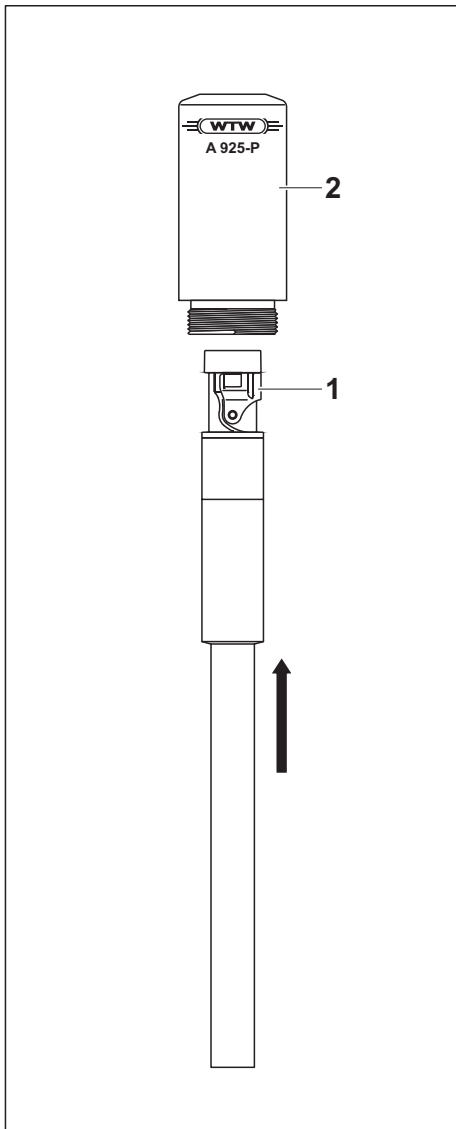

Figure 1

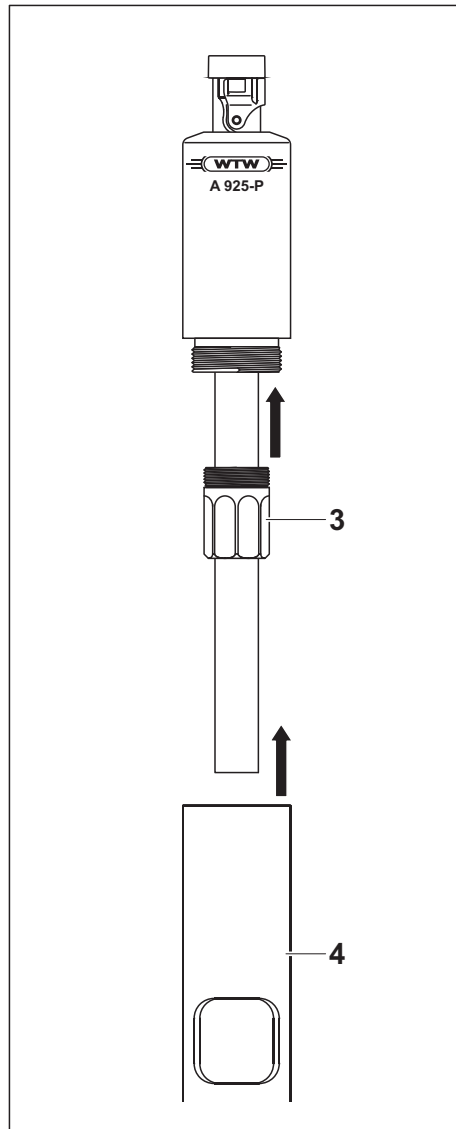

Figure 2

Installation

Installing the sensor

1	If necessary, disconnect the sensor connection cable and fold up the lock (pos. 1 in figure 1) on the sensor <u>completely</u> .
2	Push the sensor into the head (pos. 2 in figure 1).
3	Slide the coupling ring (pos. 3 in figure 2) on the sensor and screw it into the head by hand.
4	/K and /S variants: Screw on the protective hood (pos. 4 in figure 2).

Technical data

Dimensions	Diameter	38 mm
	Lengths:	
	– A 925-P	107 mm
	– A 925-P/x	235 mm
Materials	Head	POM
	Coupling ring	POM
	Protective hood (/K variants)	POM
	Protective hood (/S variants)	Stainless steel 1.4571

Further accessories

Description	Model	Order no.
Protective lid for protective hood (/K and /S variants)	SK-325	201 580

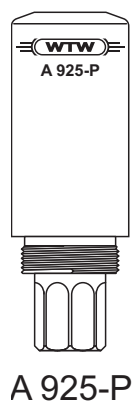

A 925-P

A 925-P/K

A 925-P/S

COQUE DE PROTECTION POUR SONDE DE TERRAIN IDS



a xylem brand

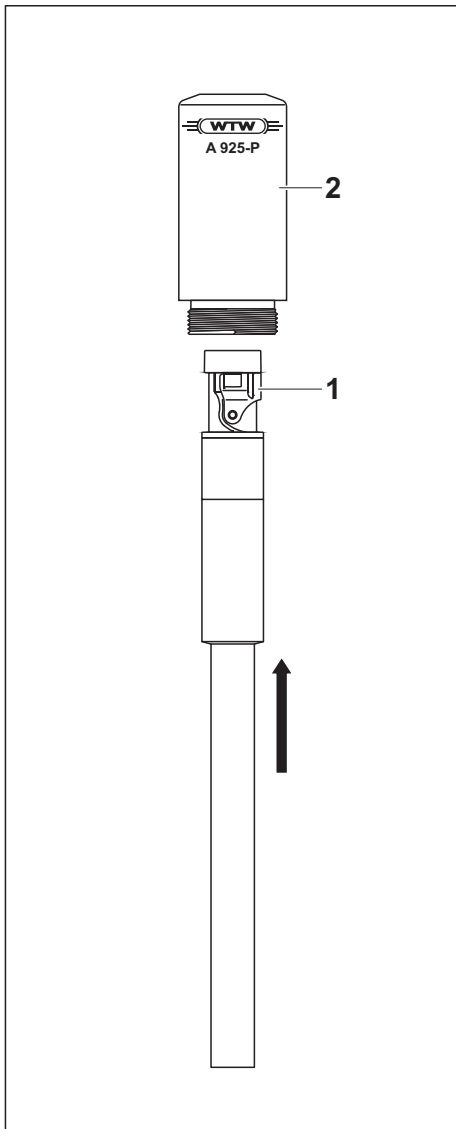

Fig. 1

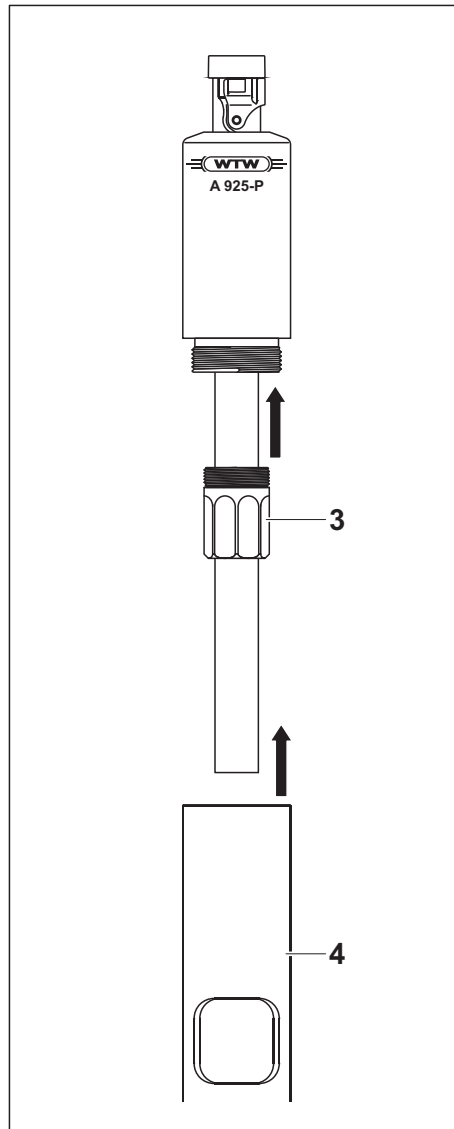

Fig. 2

Montage

Montage de la sonde

1	Si besoin, débrancher le câble de raccordement de la sonde et rabattre <u>complètement</u> le verrouillage (pos. 1, fig. 1) sur la sonde.
2	Pousser la sonde dans la tête (pos. 2 fig. 1).
3	Pousser l'écrou-raccord (pos. 3 fig. 2) sur la sonde et le visser à la main dans la tête.
4	Variante /K et /S: Visser la corbeille de protection par dessus (pos. 4 fig. 2).

Caractéristiques techniques

Dimensions	Diamètre	38 mm
	Longueurs:	
	– A 925-P	107 mm
	– A 925-P/x	235 mm
Matières	Tête	POM
	Écrou-raccord	POM
	Corbeille de protection (variante /K)	POM
	Corbeille de protection (variante /S)	Acier spécial 1.4571

Autres accessoires

Description	Modèle	Référence
Couvercle de protection pour la corbeille de protection (variantes /K et /S)	SK-325	201 580

INSTRUCCIONES DE OPERACIÓN

ba77017s01 10/2013

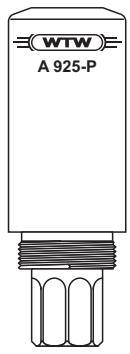

A 925-P



A 925-P/K
A 925-P/S

A 925-P A 925-P/K A 925-P/S

REFUERZO DE PROTECCIÓN PARA LOS SENSORES IDS SOBRE TERRENO



a xylem brand



Figura 1



Figura 2

Montaje

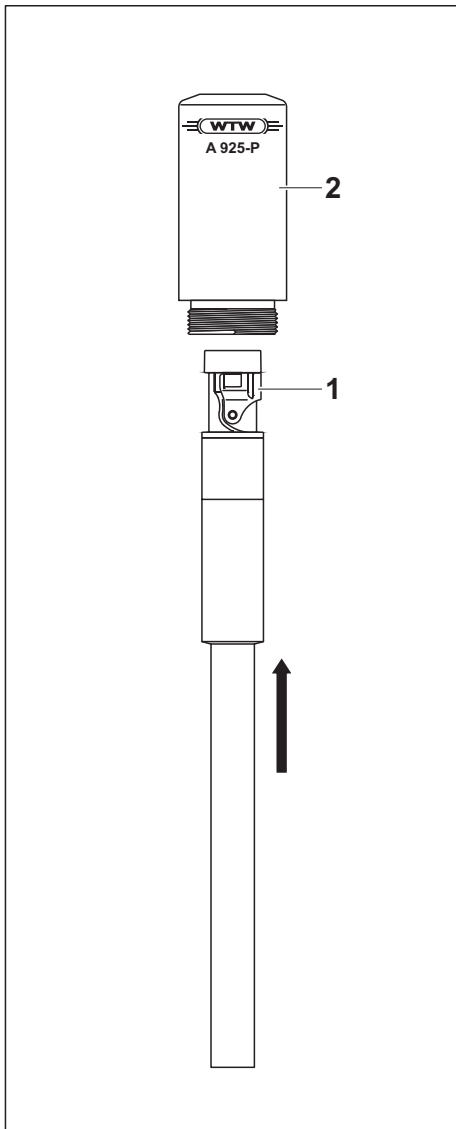
Instalación del sensor

1	En caso necesario, desenchufar el cable de conexión del sensor y rebatir <u>completamente</u> el mecanismo de bloqueo (pos. 1 en la figura 1).
2	Introducir el sensor en el cabezal (pos. 2 en la figura 1).
3	Desplazar la tuerca tapón (pos. 3 en la figura 2) por encima del sensor y atornillarla a mano en el cabezal.
4	Variantes /K y /S: Atornillar el canastillo de protección (pos. 4 en la figura 2).

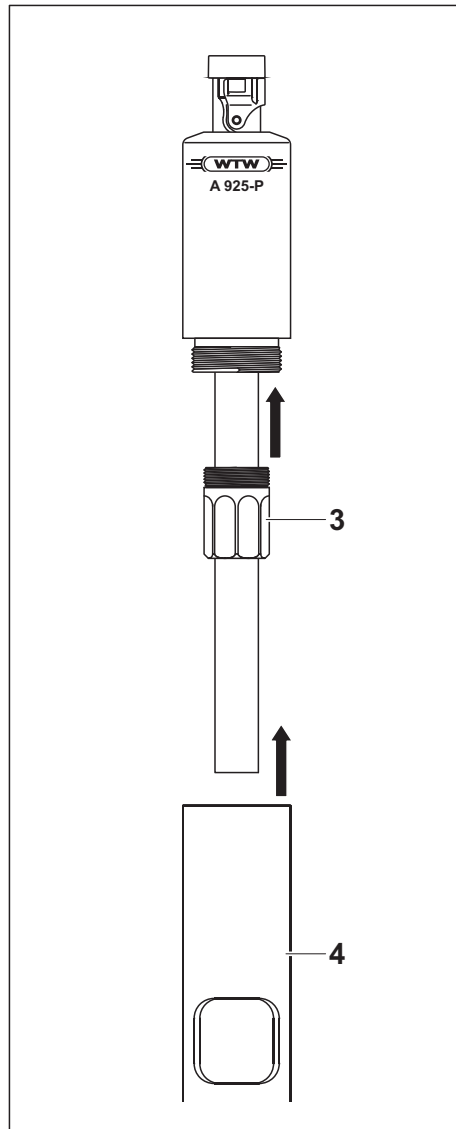
Especificaciones técnicas

Dimensiones

Diámetro	38 mm
Longitudes:	
– A 925-P	107 mm
– A 925-P/x	235 mm

Materiales

Cabezal	POM
Tuerca tapón	POM
Canastillo de protección (variantes /K)	POM
Canastillo de protección (variantes /S)	Acero inoxidable 1.4571

Otros accesorios

Descripción del funcionamiento	Modelo no.:	No. de pedido
Tapa del canastillo de protección (variantes /K y /S)	SK-325	201 580

Xylem |'zīləm|

- 1) The tissue in plants that brings water upward from the roots;
- 2) a leading global water technology company.

We're 12,500 people unified in a common purpose: creating innovative solutions to meet our world's water needs. Developing new technologies that will improve the way water is used, conserved, and re-used in the future is central to our work. We move, treat, analyze, and return water to the environment, and we help people use water efficiently, in their homes, buildings, factories and farms. In more than 150 countries, we have strong, long-standing relationships with customers who know us for our powerful combination of leading product brands and applications expertise, backed by a legacy of innovation.

For more information on how Xylem can help you, go to www.xylem.com



Wissenschaftlich-Technische Werkstätten GmbH

Dr.-Karl-Slevogt-Straße 1
D-82362 Weilheim
Germany

Tel: +49 881 183-0
Fax: +49 881 183-420
E-Mail: info@wtw.com
Internet: www.wtw.com